



TECHNICAL SPECS: UV GREEN CLEAN BIO-WALL MAX 50"
HVAC DUCT MOUNTED UV-C AIR DISINFECTION SYSTEM
FOR CANNABIS GROW FACILITIES



Description

The UV GREEN CLEAN BIO-WALL MAX 50" is a high intensity UVC air disinfection system designed to be mounted in the return or supply ducting of the HVAC System. The Bio-Wall Max 50" will destroy the harmful biological contaminants found within a Cannabis grow facility such as Powdery Mildew, Botrytis, Gray Mold, Downey Mildew, Bacteria and other associated airborne contaminants that can be harmful to the plants and terpenes. The Bio-Wall Max 50" is designed to be used in tandem with your HVAC system to prevent the outbreak of Powdery Mildew, and to allow the grower the most consistent product through the removal of all airborne pathogens.

UNIT/STANDARD EQUIPMENT part number: **GCB10M50-G**

- Aluminum reflector assembly/steel ballast box casing. Combined shipping weight 49 lbs
- Lamp reflector assembly dimension: 5.25 in diameter x 56 in length
- Ballast box dimension: 19.4 in in height x 3.2 in in depth x 15.4 in length
- Whole unit consumption: 120v /240v – 636 Watts @120v. Hardwire to Power Source
- Remote 7" Display screen for lamp monitoring
- Dry contact(s) in ballast box for BMS – ON/OFF remotely + contact for door cut off switch
- 5 – 50" straight UVC Lamps (part no. LMPHGS500)
- UVC 254nm lamp wavelength
- 5 – 120v/240v multi voltage ballasts (partBST120/277SHS)
- 5 – High intensity aluminum reflectors
- ETL C/US Listed
- **Warranty:** ballast-15 years, lamp-2 years

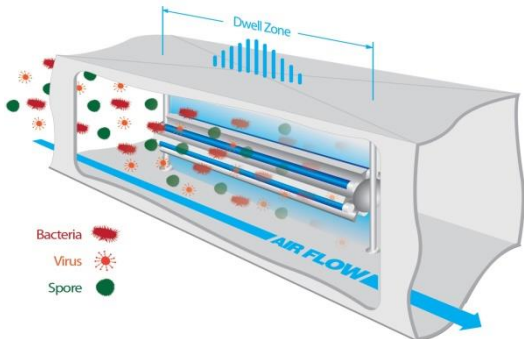
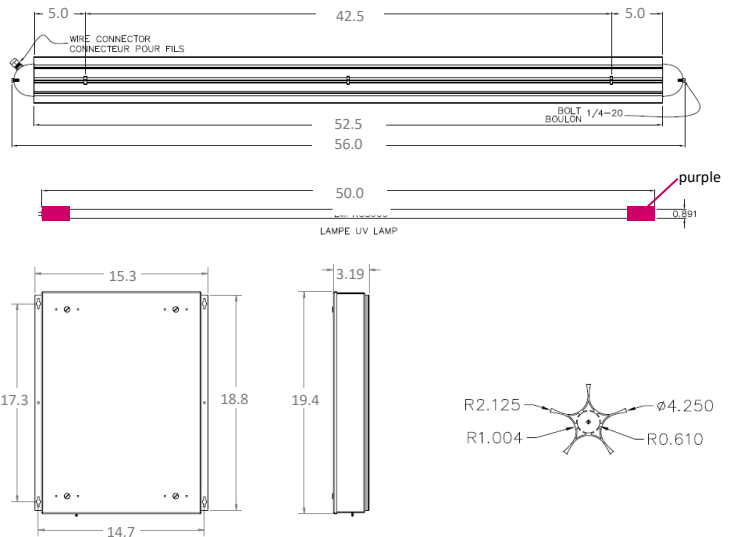

QTY:	
PROJECT:	
LOCATION:	
ARCHITECT:	
ENGINEER:	
CONTRACTOR:	
DATE:	
NOTES:	

Drawings for:
 information approval